

BUILD IT WITH
REDWOOD

Freestanding Deck



REDWOOD

Naturally beautiful
Easy to use
Practical and economical
Durable and stable
Resistant to decay and insects

Freestanding Deck

Transform the ordinary outdoors into an inviting entertainment center for family and friends with the addition of a well-proportioned freestanding 8x10 redwood deck.

The knotty redwood garden grades, such as Construction Common or Deck Common, are top choices for their visual character and economy. For increased decay resistance, choose the all-heartwood grades, Construction Heart or Deck Heart, especially for decking or framing that will be built on or near the ground.

BUILD A REDWOOD DECK

This small deck can make a big difference at a garden doorway, next to a retaining wall or under your favorite tree. It is relatively easy to build and won't cost too much either.

First decide the placement and height of the deck. Most building codes require railings on decks that will be higher than 18 inches off the ground. You can build a freestanding deck or one that is attached to the side of your house.

To attach the deck to the house use the simplest anchoring system permitted by local building codes. A typical design is shown on the back panels of this brochure.

FREESTANDING 8 X 10 DECK

It is always a good idea to measure and cut as you build for the most accurate results. Use non-corrosive, hot-dipped galvanized, stainless steel or aluminum fasteners and hardware. To minimize splitting, predrill nail holes at board ends.

1. Layout Mark the deck corners with stakes and string. Use a carpenter's square to help lay out 90° corners. Double check for squareness by measuring diagonally between the corners. If the two diagonal measurements are equal, the layout is a true rectangle.

2. Footings and posts Simple precast concrete footings with wood nailing blocks are used in this design. For this freestanding deck, you will need six. Check local building codes to be sure these footings are appropriate for your climate. Once your footings are set, place the 4x4 posts in position.

Post lengths will vary according to the contour of the ground. Establish the height at one corner and use this to measure the others.

Accurate measurement and trimming of the posts can be achieved using a string level or a carpenter's level. Post tops should be 1½ inches below the top of the skirtboards. This provides room for the deck boards. Toenail posts to the footings.

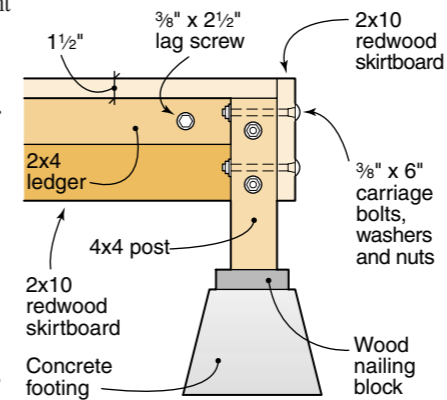

3. Skirtboards and ledgers The skirtboards can be 2x10 lumber, which will conceal the 2x8 joists of the deck framing, or they can be 2x12 lumber which will give the deck a more substantial appearance. First, trim the eight-foot long skirtboards to 93¾ inches. After trimming two 2x4 ledgers to 83¾ inches, center them lengthwise on the trimmed skirtboards, 1½ inches from the top edge. Attach the ledgers with five equally-spaced ¾-inch by 2½-inch lag screws per ledger. The ledgers will support the ends of the decking.

Drill two ¾-inch pilot holes into the posts per joint, staggering them to allow for the other skirtboard joint. Use ¾-inch by 6-inch carriage bolts, washers and nuts to attach the long-side skirtboards. Install the short-side skirtboards next, lapping the ends of the long-side skirtboards.

4. Joists Attach 2x8 joists using metal joist hangers. Leave room so that the decking will be even with the top of the skirtboards. Space the joists 24 inches on center, which means the center of one joist is 24 inches from the next. To ensure vertical joists, mark their positions using a carpenter's square as a guide. Fasten the joist hangers to the

skirtboard with 1¼-inch joist hanger nails before installing the joists. Use a scrap piece of 2x8 lumber as a spacer in the joist hangers while nailing them to the skirtboard. This will assure a proper final fit.

5. Decking Lay the 25 2x4 deck boards on the joists. Do not fasten the boards in place until you are satisfied with their arrangement and spacing. Install deck boards bark side up. Predrill nail holes near the ends of boards to prevent splitting. Attach decking with 16d nails or 3-inch deck screws. Allow ⅛-inch space between all deck boards including those next to the skirtboards.

Optional 2x6 decking If you choose 2x6 redwood decking to cover your deck, you will need 16 pieces and the short-side skirtboards and ledgers will now trim to 93⅛ and 83⅛ inches long, respectively. Remember to lay out the deck boards before securing them and to allow ⅛-inch spaces between all deckboards.

Tools you will need Tape measure, carpenter's or framing square, hammer, ratchet wrench, power radial saw, plumb, line level and level, power drill and regular bits and rubber mallet.

Materials For Freestanding 8x10 Deck

	Quantity	Size	Length
Posts	6	4x4	varied
Skirtboard, long side	2	2x10*	10 feet
Skirtboard, short side	2	2x10*	8 feet
Ledgers	2	2x4	8 feet
Joists	4	2x8	8 feet
Deck boards	26	2x4	10 feet
or Deck boards	16	2x6	10 feet
Deck screws	1 pound	3 inches	
or nails	1½ pounds	16d	
Joist hangers	8	2x8	
Joist nails	1½ pounds	1¼ inches	
Lag Screws	10	¾ x 2½ inches	
Carriage bolts, washers and nuts	20 sets	¾ x 6 inches	
Concrete footings	6		

*or can be 2x12 redwood lumber

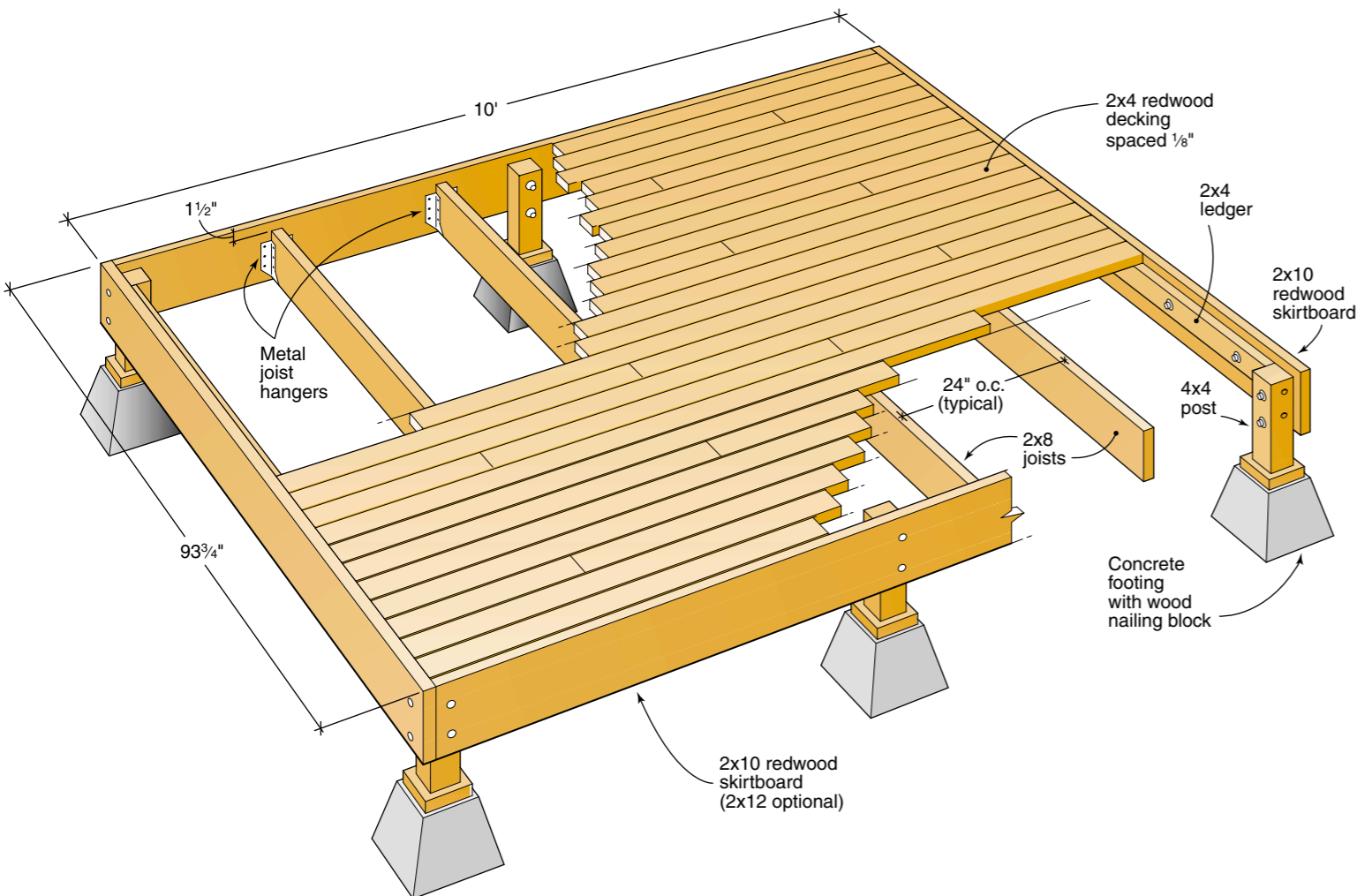

ATTACHED 8 X 10 DECK

A deck that is attached to a house is supported at the house wall by a board called a ledger. Building with a ledger eliminates three posts and footings, and one skirtboard from the deck design. The ledger must be securely anchored into the house framing (band joist) in order to support the deck's weight. Ledger attachments must also be moisture proofed. Install the 2x8 ledger so that the decking will be at least 1 inch below the indoor floor level. The illustrations show the most typical ledger attachment and detail an alternate technique for using washers as spacers. Both will allow water to drain away from the house and deck, preventing water damage. A portion of the siding must be removed where the ledger attaches to the house wall. Allow room for the skirtboards that attach to the ends of the ledger.

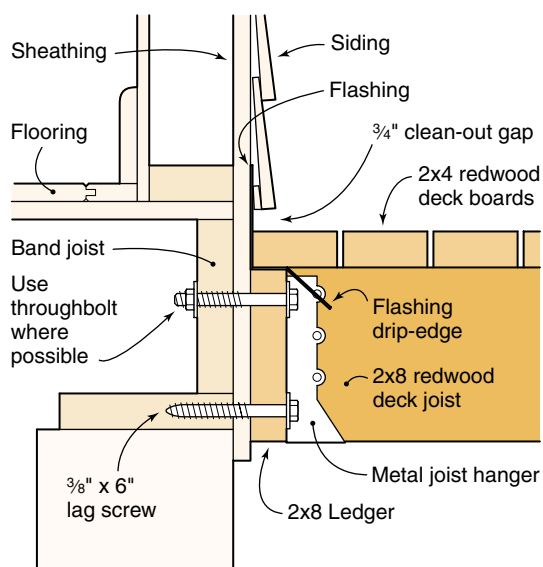

Flashed ledger Trim the galvanized metal flashing to the length of the cutout. Insert the flashing under the siding and fold it up and out of the way until the ledger is attached.

Brace the 2x8 ledger into position and drill pairs of 1/4-inch pilot holes spaced no more than 24 inches apart through the ledger, sheathing and into the house framing. Secure the ledger to the house with 3/8-inch by 5-inch lag screws and washers, penetrating the house framing by at least 1 1/2 inches. Where you have through access, use 3/8-inch by 6-inch carriage bolts, washers and nuts.

Use siliconized acrylic caulking in the bolt holes and around the bolt heads after securing them in the ledger. Also seal the ends and bottom of the ledger where it meets the house. Fold the flashing over the top of the 2x8 ledger and bend it to direct water away from the house and ledger as shown.

Washers as spacers

Use stainless steel or top quality galvanized washers and install enough to allow at least a 1/2-inch space between the house wall and the ledger.

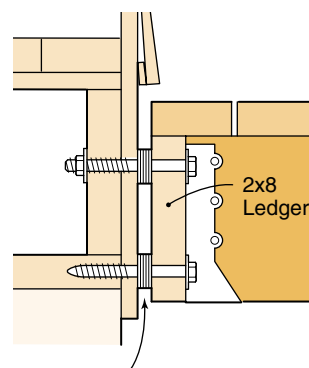

Galvanized or stainless steel washers for 1/2" spacing

Additional tools needed Metal snips, siliconized acrylic caulking and caulking gun. The materials listed below include only those which are different or in addition to those listed for the Freestanding 8x10 deck.

Additional Materials For Attached 8x10 Deck

	Quantity	Size	Length
Ledger	1	2x8	10 feet
Posts	3	4x4	varied
Skirtboard	1	2x10	10 feet
Concrete footings	3		
Carriage bolts, washers and nuts	10 sets	3/8 inch	6 inches
or Lag screws and washers	10 sets	3/8 inch	5 inches
Galvanized metal flashing	as needed		10 feet

Contact the California Redwood Association for more great publications containing redwood technical and building information. Call us toll free at 1-888-Cal-Redwood for a complete literature list or to ask for any of the titles listed here:

Other Construction Tipsheets

Deck Over Concrete
Calistoga Spa Surround
Windsor Shade Shelter
Monterey Potting Center
Mendocino Bench
Lake Tahoe Gazebo
Petaluma Planters
Sonoma Picnic Table

Also Available

Deck Construction
Deck Grades, Nails and Finishes
Fences for All Reasons
Landscape Architecture

Redwood

For beauty and performance, redwood is naturally superior to other woods. That's why it's the first choice for decks, fences and most outdoor projects. Redwood retains its beauty outdoors, shrinks and swells less than other woods and is less likely to warp, split, check or cup. With relatively little or no pitch, redwood is easy to drill, saw and shape. Redwood heartwood has natural durability and resistance to insects and will last longer outdoors than most woods.

Grades

The knotty garden grades of redwood are ideal for outdoor projects. These grades are beautiful, durable and economical.

Construction Heart/Deck Heart is all heartwood and contains knots; used for load-bearing applications near the ground. Deck Heart is graded for strength and is available in 2x4 and 2x6.

Construction Common/Deck Common contains sapwood and knots; used for decking and above-ground uses. Deck Common is graded for strength and is available in 2x4 and 2x6.

Merchantable Heart is all heartwood and contains larger knots than Construction grades; used near the soil.

Merchantable contains sapwood and larger knots; used for fence boards, rails and above-ground uses.

Finishes

Redwood accepts finishes better than most woods. Some heighten redwood's natural beauty, bringing out the color and the grain. Others help the wood harmonize or contrast with surrounding structures. Read the labels on all finish products before using.

No-finish option Redwood performs better than most woods if left unfinished. This no-maintenance option will result in redwood weather-bleaching to a soft driftwood gray.

Clear water repellent finish with mildewcide is recommended to stabilize the color at tan.

Bleaching and weathering stains produce a permanent driftwood gray effect, a good, low-maintenance option.

Semitransparent stains in "redwood" shades tint the wood without hiding the grain.

Solid-color stains or paints should be applied over compatible oil-based primers.

Fasteners

Use only non-corrosive hardware such as aluminum, stainless steel or top quality hot-dipped galvanized screws or nails. Ordinary nails and screws will cause stains.



405 Enfrente Drive, Suite 200
Novato, CA 94949-7206
Telephone 415 382-0662
Toll Free 888 Cal-Redwood
Fax 415 382-8531
www.calredwood.org